



For Models 7001, 7002

## FREDDY FENDERS CLIP-ONS MOUNTING INSTRUCTIONS

### A MOUNTING FRONT FENDER

- 
- **A1.** Pass the 18 mm hex-head bolt through from underside of front fender. It should fit flush in molded holder.□
- 
- **A2.** Put the steel hanger on the 18 mm bolt then push the hanger forward. Use the quick release nut to secure the steel hanger to the fender.□
- 
- **A3.** Screw the steel hanger behind front fork with 48 mm bolt, plastic concave washer, flat washer and lock nut, as illustrated in diagram to the right.

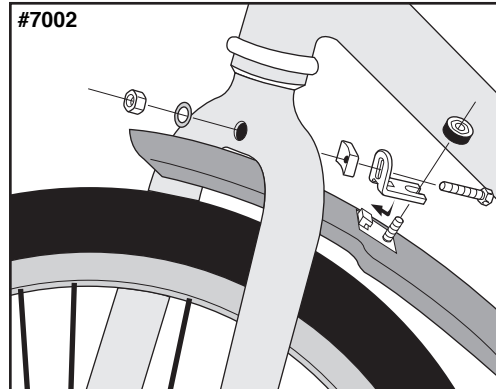

### MOUNTING REAR FENDER

- 
- **B**
- **B1.** If seat stay bridge is plate type or larger than 1/2" in diameter, clip the plastic hanger on rear fender as in diagram 1B. If not, proceed to C1.□
- 
- **B2.** Clip the front part of the fender on seat tube. Attach the plastic hanger on seat stay bridge with the 32 mm bolt, flat washer and lock nut as in diagram 2B. Extra plastic concave washers are included for larger bridge tubes.□
- 
- **B3.** If bridge has no hole or there is no bridge, use 2 zip ties going through channels in plastic clip then tighten around each seat stay.□
- 
- 
- **C**
- **C1.** If seat stay bridge tube is 1/2" in diameter or smaller, clip the plastic hanger on rear fender as in diagram 1C.□
- 
- **C2.** Clip the front part of rear fender on seat tube. Plastic hanger can be clamped firmly on bridge tube without using screw, washer and nut as seen in diagram 2C. If hanger is not tight, refer to B2 above.

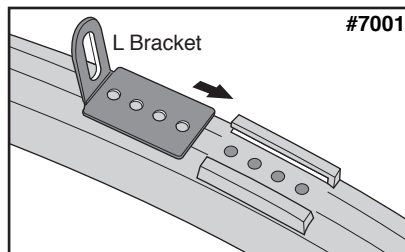
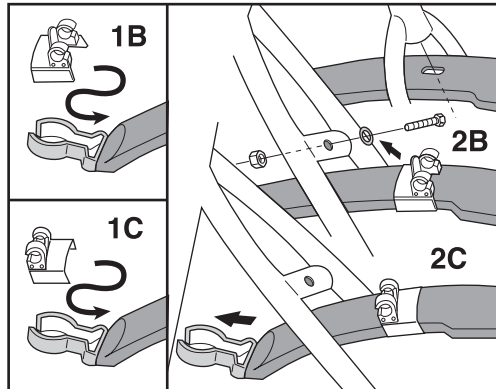

For #7001 FRONT and REAR fenders,□  
slide metal L Bracket onto fender as shown.□

For front fender, refer to A3 above.□  
For rear fender, refer to B2 and B3 above.